

Air Cooled  
Condensers

**HTC**

# Air Cooled Condensers

# HTC

## Contents

Page	
3	General information
4 - 9	Nominal duty, dimensions, air flow, sound levels
10	Fan types Fan motors
11	Capacity calculation Correction factors
12 - 13	Technical data
14	Extended feet Additional information

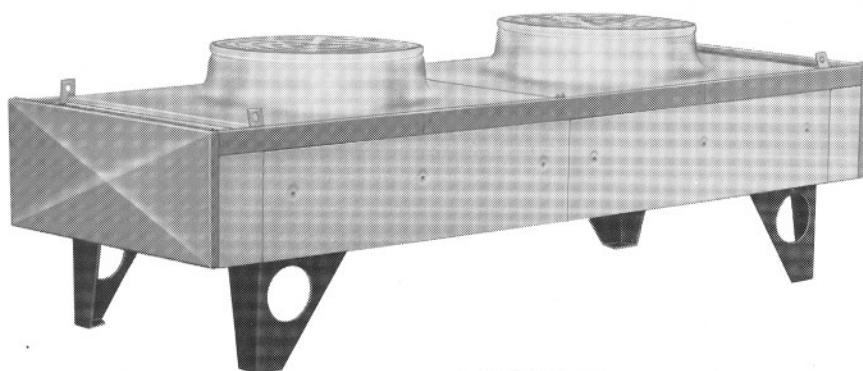

HTC type 2

## Type indication

Example : **HTC 2 . 124 - 930**

**HTC** : Air cooled condenser with Cu/Al coil block

**2** : Condenser type  
There are 4 basic types with different fan diameters

**1••** : Number of separated coils

**•2•** : Number of fans per coil

**••4** : Number of tube rows in air direction

**930** : Fan speed

## Air Cooled Condensers

## HTC

### General

The HTC aircooled condenser range includes 4 basic types covering over 200 models with 1 to 12 fans and duties from 9 to 820 kW at 15 K temperature difference.

### Design

Copper Ripple Fin<sup>®</sup> tubing with aluminium fins.

Tube diameter : 1/2"

Tube pitch : 50 x 50 mm triangle

Fin spacing : 2.25 mm

Other fin spacings up to 4 mm available on request.

Casing and framework are of pregalvanised sheet steel (Sendzimir) with an epoxy coating on both sides in an attractive colour scheme: light-grey RAL 7035, blue RAL 5007 and dark-grey RAL 7031. Other colours are available as optional extra.

All condensers are provided with header panels.

Header- and side panels are removable for inspection and cleaning.

All condensers are pressure tested at 25 bar dry air.

The condensers can be supplied (at extra cost) with additional coil circuits.

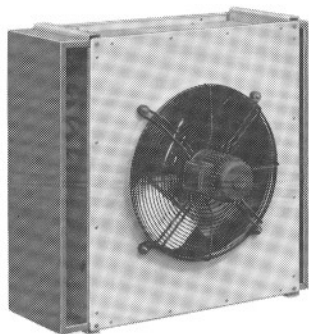

HTC type 3

### Air direction

Condensers type HTC can be supplied for horizontal or vertical air flow.

#### Condensers type 1 :

Standard horizontal air flow

Vertical air flow with special refrigerant circuiting.

In case of vertical air flow mounting, hot-dipped galvanized steel support legs are available at an extra price. (type MP-4 including bolts and nuts).

#### Condenser types 2, 3 and 4 :

standard vertical air flow.

On request also available for horizontal air flow. (Some types with special circuiting design at an extra price, see tables on pages 12 and 13).

When ordering without air flow indication, the standard execution will be supplied.

### Corrosion protection

The standard condensers have a high corrosion resistance through selected materials, surface treatment and construction. For application in aggressive surroundings (coastal- and industrial areas) following designs are available at an extra charge:

- fins of seawater resistant aluminium alloy (57S/5052)
- fins of prepainted aluminium
- finned coils chromated after assembling
- copper fins (delivery time on request)

### Application as liquid cooler (Dry - Cooler)

The condenser can also be used as liquid cooler, for instance cooling down of cooling water in watercooled plants.

Technical information on request, see brochure nr. 53.08 (Liquid Coolers HTD).

HTC type 1

# Air Cooled Condensers

# HTC

HTC 1 . 1 Horizontal air flow

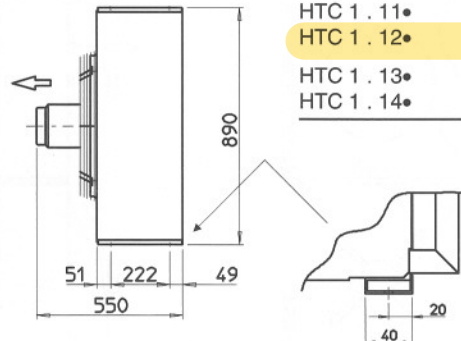
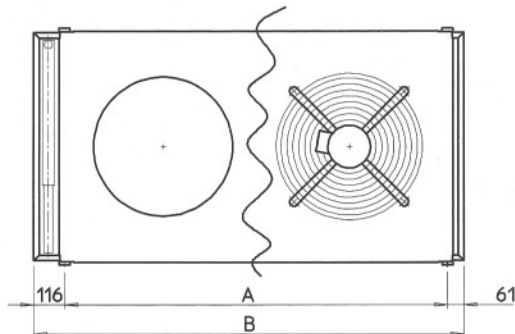

Dimensions

	A	B
HTC 1 . 11●	740	917
HTC 1 . 12●	1440	1617
HTC 1 . 13●	2140	2317
HTC 1 . 14●	2840	3017

HTC 1 . 1 Vertical air flow

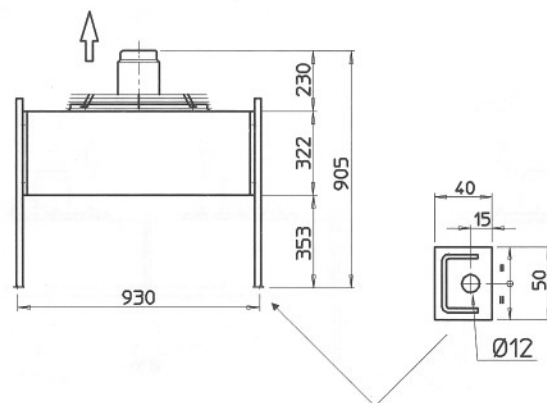
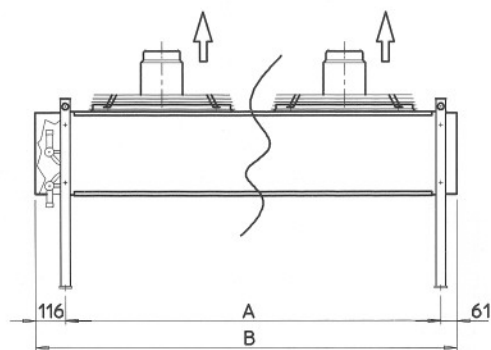

HTC 2 . 1 / 3 . 1 / 4 . 1 Horizontal air flow

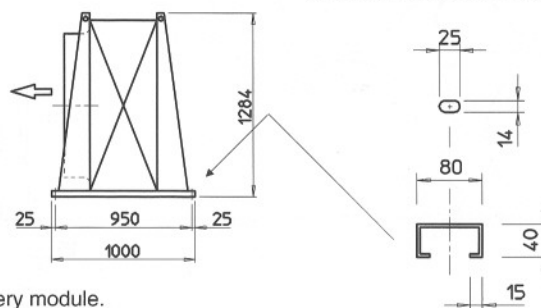
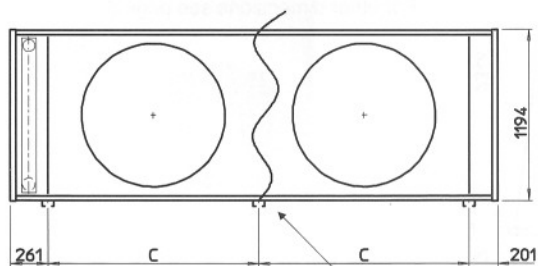

Supports for every module.

Dimensions

	C
HTC 2 . 1●●	1222
HTC 3 . 1●●	1472
HTC 4 . 1●●	1472

For other dimensions see page 9.

Air Cooled Condensers

HTC

Type	Capacity kW		Airflow m <sup>3</sup> /h		dB(A)	Capacity kW		Airflow m <sup>3</sup> /h		dB(A)	Cap.	Air	dB(A)	Cap.	Air	dB(A)
	H	L	H	L		H/L	H	L	H							
<b>Motor 370 W, 1420 rpm</b>					<b>180 W, 910 rpm</b>					<b>120 W, 690 rpm</b>			<b>25 W, 470 rpm</b>			
1.112-...	15.8		6620		55	14.0		5040		44	12.2	4160	40	9.3	2580	31
1.113-...	21.3		6540		55	18.2		4880		44	15.2	4020	40	11.2	2490	31
1.114-...	25.5		6460		55	21.1		4710		44	17.3	3840	40	12.0	2310	31
1.122-...	31.9		13200		58	28.3		10100		47	24.3	8310	43	18.6	5170	34
1.123-...	42.8		13100		58	36.8		9760		47	30.7	8040	43	22.6	4970	34
1.124-...	51.6		12900		58	42.6		9430		47	34.8	7700	43	24.0	4620	34
1.132-...	48.3		19900		60	42.6		15100		49	36.8	12400	45	28.1	7740	36
1.133-...	63.2		19600		60	54.5		14600		49	46.0	12100	45	33.9	7460	36
1.134-...	76.1		19400		60	63.3		14100		49	51.8	11600	45	35.2	6930	36
1.143-...	81.1		26200		61	71.2		19500		50	60.8	16100	46	44.7	9940	37
1.144-...	99.1		25800		61	83.2		18900		50	68.4	15400	46	47.2	9230	37
<b>Motor 750 W, 930 rpm</b>					<b>750/150 W, 935/425 rpm</b>					<b>370 W, 690 rpm</b>			<b>120 W, 325 rpm</b>			
2.112-...	38.2		15800		53	38.2	26.7	15800	8490	53/39	32.7	11200	46	23.1	6500	33
2.113-...	50.2		15100		53	50.2	33.5	15100	8300	53/39	42.1	10600	46	27.1	6080	33
2.114-...	59.3		14400		53	59.3	37.8	14400	8120	53/39	47.7	10100	46	27.4	5400	33
2.122-...	76.7		31600		56	76.7	53.5	31600	17000	56/42	65.4	22400	49	46.4	13000	36
2.123-...	100.3		30200		56	100.3	67.4	30200	16600	56/42	83.3	21200	49	55.1	12100	36
2.124-...	115.7		28700		56	115.7	75.5	28700	16200	56/42	94.0	20200	49	55.7	10800	36
2.132-...	114.1		47400		58	114.1	80.5	47400	25400	58/44	97.8	33500	51	69.2	19600	38
2.133-...	152.1		45300		58	152.1	100.1	45300	24900	58/44	125.4	31800	51	81.7	18200	38
2.134-...	176.0		43100		58	176.0	114.2	43100	24300	58/44	142.9	30400	51	83.6	16200	38
2.142-...	153.8		63300		59	153.8	107.1	63300	34000	59/45	131.1	44700	52	92.9	26000	39
2.143-...	202.3		60400		59	202.3	135.4	60400	33200	59/45	167.6	42500	52	110.5	24300	39
2.144-...	234.0		57400		59	234.0	151.9	57400	32600	59/45	189.9	40500	52	111.9	21600	39
2.152-...	192.2		79100		60	192.2	134.5	79100	42400	60/46	164.1	55900	53	116.0	32600	40
2.153-...	250.0		75500		60	250.0	167.3	75500	41400	60/46	208.4	53100	53	135.4	30300	40
2.154-...	286.3		71800		60	286.3	187.9	71800	40700	60/46	233.9	50600	53	139.5	27000	40
2.162-...	229.7		94900		61	229.7	161.5	94900	50900	61/47	196.6	67100	54	138.8	39000	41
2.163-...	304.2		90600		61	304.2	203.4	90600	49800	61/47	251.9	64000	54	163.3	36400	41
2.164-...	353.5		86100		61	353.5	228.8	86100	48800	61/47	286.6	60700	54	167.4	32400	41
<b>Motor 1400/810 W, 870/620 rpm</b>					<b>720/440 W, 680/500 rpm</b>											
3.112-...	46.4	40.6	19100	14200	57/48	41.6	37.2	15000	13300	50/41						
3.113-...	60.5	51.4	18100	13300	57/48	52.9	46.2	13900	12400	50/41						
3.114-...	70.6	57.4	17300	12400	57/48	59.9	51.8	13100	11700	50/41						
3.122-...	92.6	81.2	38200	28400	60/51	83.1	74.3	30100	26600	53/44						
3.123-...	119.8	101.6	36200	26500	60/51	104.4	92.8	27900	24900	53/44						
3.124-...	137.4	113.7	34600	24800	60/51	117.4	102.8	26200	23400	53/44						
3.132-...	136.1	120.1	57300	42700	62/53	122.7	110.3	45100	39900	55/46						
3.133-...	181.8	154.0	54400	39800	62/53	159.3	139.2	41800	37200	55/46						
3.134-...	211.5	173.4	51900	37200	62/53	179.6	156.6	39300	35100	55/46						
3.142-...	186.1	161.9	76300	56900	63/54	166.7	149.0	60100	53200	56/47						
3.143-...	240.9	205.0	72500	53000	63/54	210.6	184.6	55700	49700	56/47						
3.144-...	278.8	227.9	69200	49700	63/54	237.4	204.6	52400	46800	56/47						
3.152-...	231.1	202.6	95400	71100	64/55	207.8	185.5	75200	66400	57/48						
3.153-...	303.1	256.5	90600	66300	64/55	265.6	233.4	69700	62100	57/48						
3.154-...	356.1	288.6	86500	62100	64/55	300.2	259.8	65500	58400	57/48						
<b>Motor 2100/1200 W, 645/455 rpm</b>					<b>380/190 W, 295/180 rpm</b>											
4.112-...	53.0	46.2	26600	19300	55/47	31.1	22.5	9560	5890	36/27						
4.113-...	69.8	58.8	24200	17100	55/47	36.3	25.8	8270	5170	36/27						
4.114-...	81.5	65.5	22300	15100	55/47	36.4	25.1	7270	4600	36/27						
4.122-...	105.7	92.7	53300	38500	58/50	62.0	46.0	19100	11800	39/30						
4.123-...	136.2	116.6	48300	34200	58/50	71.2	50.2	16600	10300	39/30						
4.124-...	164.1	131.6	44600	30300	58/50	72.8	50.3	14600	9200	39/30						
4.132-...	159.5	139.6	79900	57800	60/52	93.3	68.8	28700	17700	41/32						
4.133-...	209.4	177.4	72500	51200	60/52	106.6	76.5	24800	15600	41/32						
4.134-...	243.9	197.0	66900	45400	60/52	110.0	74.8	21800	13800	41/32						
4.142-...	212.5	186.1	107000	77000	61/53	124.2	92.1	39300	23600	42/33						
4.143-...	275.5	234.3	967000	68300	61/53	143.0	100.7	33000	20700	42/33						
4.144-...	329.4	263.8	89200	60600	61/53	145.8	100.6	29000	18400	42/33						
4.152-...	263.6	232.2	133000	96300	62/54	156.3	115.3	47800	29400	43/34						
4.153-...	348.8	295.2	121000	85400	62/54	178.5	127.0	41300	25900	43/34						
4.154-...	410.4	330.8	111000	75700	62/54	186.1	123.0	36300	23000	43/34						

H = High fan speed

L = Low fan speed

# Air Cooled Condensers

# HTC

## Fan types

All fan types have corrosion resistant fan blades and fan guards.

### HTC Type 1

Fans ø 508 mm, complete with protection guards and anti vibration mountings. The guards are galvanized and epoxy coated. Mounting bolts and nuts are stainless steel. Standard execution with fan motors type 1.910.

Terminal boxes are provided with cable inlet PG-13,5.

### HTC Type 2

Fans ø 762 mm mounted on a motor support. Fan guards are integrated in the fan plate.

Standard execution with fan motors type 2.930.

Motors are wired to a common terminal box:

HTC type 2.1 : 1 terminal box,  
HTC type 2.2 : 2 terminal boxes.

The terminal boxes are located on the end-plate at the liquid header end of the coil.

### HTC Type 3

Fans ø 800 mm, fan motors integrated with guards and mounted to fan discharge hood.

### HTC Type 4

Similar in construction to type 3, fan diameter however 1000 mm.

All fan motors of HTC models 3 and 4 are equipped with an overload protector built in the windings. Via terminals in the terminal box this internal protector **must** be used in the control current circuit. The electrical control should be arranged in such a way that continuous on/off switching of the motors ('tripping') is prevented.

When the condensers are out of use for longer periods, the motors have to be switched on for at least 2 hours every month.

### HTC types 1 t/m 4

For application at ambient temperatures above 40 °C : special motors on request.

## Fan motors

Motor type	Nr. of poles	rpm	Watt	Voltage	Thermal overload relay * settings (A)
------------	--------------	-----	------	---------	---------------------------------------

### HTC type 1 (enclosed design, IP-55)

1.910	6	910	180	220/380/50/3	0.86
1.690	8	690	120	220/380/50/3	0.67
1.470	12	470	25	220/380/50/3	0.32
1.1420	4	1420	370	220/380/50/3	1.4
1.VAR	6	variable	180	220/50/1	2.36 **

### HTC type 2 (enclosed design, IP-55)

2.930	6	930	750	220-240/380-415/50/3	2.9/5.0
2.690	8	690	370	220-240/380-415/50/3	1.5/2.6
2.325	16	325	120	220-240/380-415/50/3	1.2/2.0
2.425	YI 6	935	750	380-415/50/3	3.1
	YII 12	425	150	380-415/50/3	1.1
2.930 W	6	930	750	220-240/50/1	8.0
2.VAR	6	variable	750	220-240/50/1	8.4 **
2.840	8	840	660	220-254/380-440/60/3	2.8/4.8

### HTC type 3 (enclosed design, IP-44)

3.870	Y -	870	1400	380/50/3	3.2
	Δ -	620	810	380/50/3	1.9
3.680	Y -	680	720	380/50/3	2.2
	Δ -	500	440	380/50/3	1.1

### HTC type 4 (enclosed design, IP-44)

4.645	Y -	645	2100	380/50/3	4.6
	Δ -	455	1200	380/50/3	3.0
4.295	Y -	295	380	380/50/3	1.54
	Δ -	180	190	380/50/3	0.66

\* The settings can be applied to a minimum ambient temperature of -10 °C

\*\* Value at highest speed.

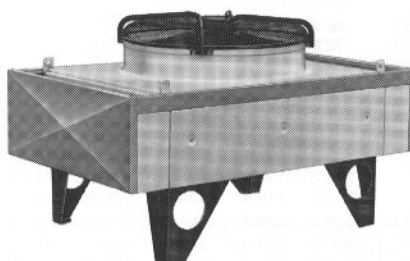

HTC type 4

# Air Cooled Condensers

# HTC

## Multi circuiting

Condensers can be supplied (at extra cost) with additional coil circuits. The capacity of each section can be obtained by deviding the total condenser capacity by the number of circuits (table).

## Soundlevel dB(A)

The soundlevels in the tables on pages 10 and 11 are the results of tests carried out in free field conditions. The values are measured in the horizontal plane at a distance of 10 m around the condenser with an A-filter.

Values may deviate depending on situations at site (f.i. horizontal air flow). More information on request.

The table below gives sound level corrections at various distances.

Distance m	Correction dB(A)
1	+ 20
2	+ 14
3	+ 10
4	+ 8
5	+ 6
10	0
20	- 6
50	- 14
100	- 20

★ These condenser types have the connections on both ends (inlet connection has been moved). All other models have the inlet- and outlet connections at the same side.

★★ Without changes in circuiting design suitable for horizontal air flow.

## Technical data HTC • 1 ••

Type	Refrigerant connections mm ODS		Max. number separated refrigerant circuits	Internal volume dm <sup>3</sup>	Surface		Weight kg fin execution		
	in	out			m <sup>2</sup>	aluminium	copper		
1.112 - ...	1 x 22	1 x 22	2	4	41	41	54		
1.113 - ...	1 x 22	1 x 22	3	6	62	49	68		
1.114 - ...	1 x 22	1 x 22	4	8	82	57	82		
1.122 - ...	1 x 22	1 x 22	4	7	82	80	105		
1.123 - ...	1 x 28	1 x 22	6	10	123	95	133		
1.124 - ...	1 x 28	1 x 28	8	14	164	110	161		
1.132 - ...	1 x 28	1 x 28	8	10	123	119	157		
1.133 - ...	1 x 35	1 x 28	6	15	185	141	198		
1.134 - ...	1 x 35	1 x 28	8	19	246	164	239		
1.143 - ...	1 x 35	1 x 35	6	19	246	188	264		
1.144 - ...	1 x 35	1 x 35	8	25	328	217	318		
2.112 - ...	1 x 28	1 x 22	11	9	98	126	157		
2.113 - ...	1 x 28	1 x 28	11	13	147	145	190		
2.114 - ...	1 x 35	1 x 28	11	17	197	163	223		
2.122 - ...	1 x 35	1 x 35	11	15	197	250	311		
2.123 - ...	1 x 42	1 x 35	11	23	295	285	376		
2.124 - ...	1 x 42	1 x 35	11	30	393	321	442		
2.132 - ...	1 x 42	1 x 35	11	24	295	377	468		
2.133 - ...	1 x 54	1 x 42	★	★★	22	36	442	430	567
2.134 - ...	1 x 54	1 x 54	★	★★	22	48	590	484	666
2.142 - ...	1 x 54	1 x 54	★	★★	22	31	393	501	622
2.143 - ...	1 x 54	1 x 54	★	★★	22	46	590	571	753
2.144 - ...	1 x 67	1 x 54	★	★★	22	61	786	642	884
2.152 - ...	1 x 54	1 x 54	★	★★	22	37	492	625	776
2.153 - ...	1 x 67	1 x 54	★	★★	22	56	737	712	940
2.154 - ...	1 x 67	1 x 54	★	★★	22	75	983	800	1103
2.162 - ...	1 x 67	1 x 54	★★	★★	22	44	590	749	931
2.163 - ...	1 x 67	1 x 67	★★	★★	33	66	885	853	1126
2.164 - ...	1 x 80	1 x 67	★★	★★	44	88	1180	958	1321
3.112 - ...	1 x 28	1 x 28	11	10	118	228	265		
3.113 - ...	1 x 35	1 x 28	11	15	178	250	305		
3.114 - ...	1 x 35	1 x 28	11	20	237	272	345		
3.122 - ...	1 x 42	1 x 35	11	18	237	454	527		
3.123 - ...	1 x 42	1 x 42	11	27	355	496	606		
3.124 - ...	1 x 54	1 x 42	11	36	474	538	685		
3.132 - ...	1 x 54	1 x 42	11	28	355	683	792		
3.133 - ...	1 x 54	1 x 54	★	★★	22	42	533	747	911
3.134 - ...	1 x 54	1 x 54	★	★★	22	56	711	811	1030
3.142 - ...	1 x 54	1 x 54	★	★★	22	36	474	909	1055
3.143 - ...	1 x 67	1 x 54	★	★★	22	54	711	993	1212
3.144 - ...	1 x 67	1 x 54	★	★★	22	72	948	1078	1370
3.152 - ...	1 x 67	1 x 54	★★	★★	22	44	592	1135	1317
3.153 - ...	1 x 67	1 x 67	★★	★★	33	66	888	1240	1513
3.154 - ...	1 x 80	1 x 67	★★	★★	44	88	1185	1344	1710
4.112 - ...	1 x 35	1 x 28	11	10	118	238	275		
4.113 - ...	1 x 35	1 x 28	11	15	178	260	315		
4.114 - ...	1 x 35	1 x 35	11	20	237	282	355		
4.122 - ...	1 x 42	1 x 35	11	18	237	474	547		
4.123 - ...	1 x 54	1 x 42	11	27	355	516	626		
4.124 - ...	1 x 54	1 x 42	11	36	474	558	705		
4.132 - ...	1 x 54	1 x 42	★	★★	22	28	355	713	822
4.133 - ...	1 x 67	1 x 54	★	★★	22	42	533	777	941
4.134 - ...	1 x 67	1 x 54	★	★★	22	56	711	841	1060
4.142 - ...	1 x 67	1 x 54	★	★★	22	36	474	949	1095
4.143 - ...	1 x 67	1 x 54	★	★★	22	54	711	1033	1252
4.144 - ...	1 x 67	1 x 67	★	★★	44	72	948	1118	1410
4.152 - ...	1 x 67	1 x 54	★★	★★	22	44	592	1185	1367
4.153 - ...	1 x 80	1 x 67	★★	★★	33	66	888	1290	1563
4.154 - ...	1 x 80	1 x 67	★★	★★	44	88	1185	1394	1760

## Air Cooled Condensers

## HTC

### Extended feet

Extended feet can be supplied as optional extra for condenser models 2, 3 and 4. These feet are supplied separately. The standard feet height gives 402 mm free space under the condenser. Extended feet are available for heights of 650, 900 and 1400 mm. The 900 and 1400 mm feet have truss beams for additional strength.

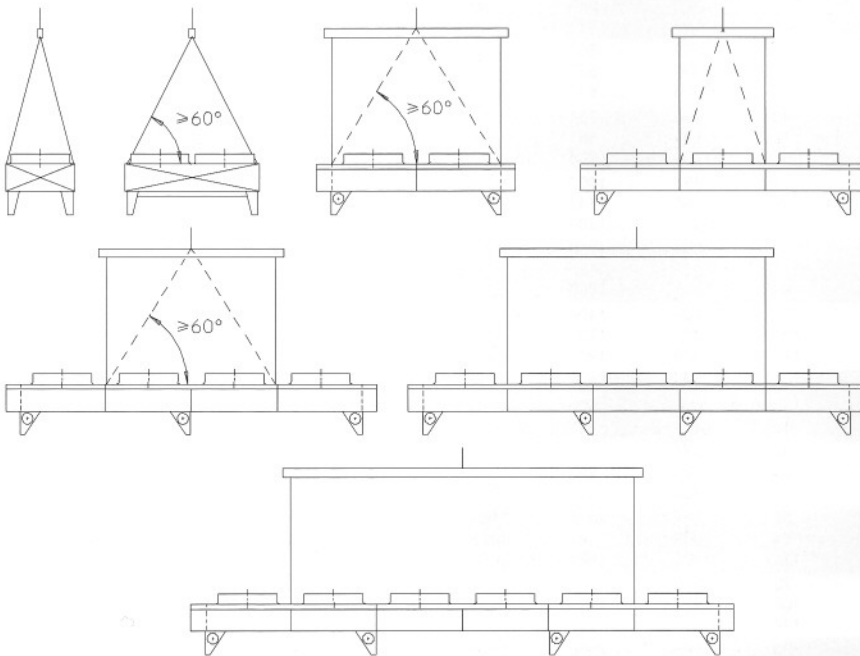

### Transport

All types are provided with lifting lugs. To avoid damage during hoisting, a hoisting beam should be used, by which the given angles are to be considered. Beware of shocks during transport and handling (sudden lifting).

### Mounting

Refrigerant pipework connections are to be soldered free of tension. When connecting more than one condenser in parallel the pressure drop on the refrigerant side has to be considered.

### Location

#### Air movement

Condensers should be positioned to achieve the following criteria :

- Adequate space (min. 1.0 metre) must be left for free entry to the coil inlet face.
- No restrictions to the air discharge.
- No possibility of direct air recirculation (short circuiting of air).

### Installation and maintenance

For more information on installation and maintenance of air cooled condensers model HTC we refer to our brochure nr. 88.02 ("Installation and Maintenance Instructions for Air Cooled Condensers"). This brochure is issued with every condenser.